

Greetings from

**KE4WMF**

York County, VA

KE4WMF.com

Icom ID-5100A

Yaesu FT-891

Yaesu FT-857D

Mobile-Only

Since 1995!



WHEN SOMEONE ASKS WHAT ALL  
IS DONE TO MY CAR



# Stealth GTI



# Inconspicuous Dual-Bander

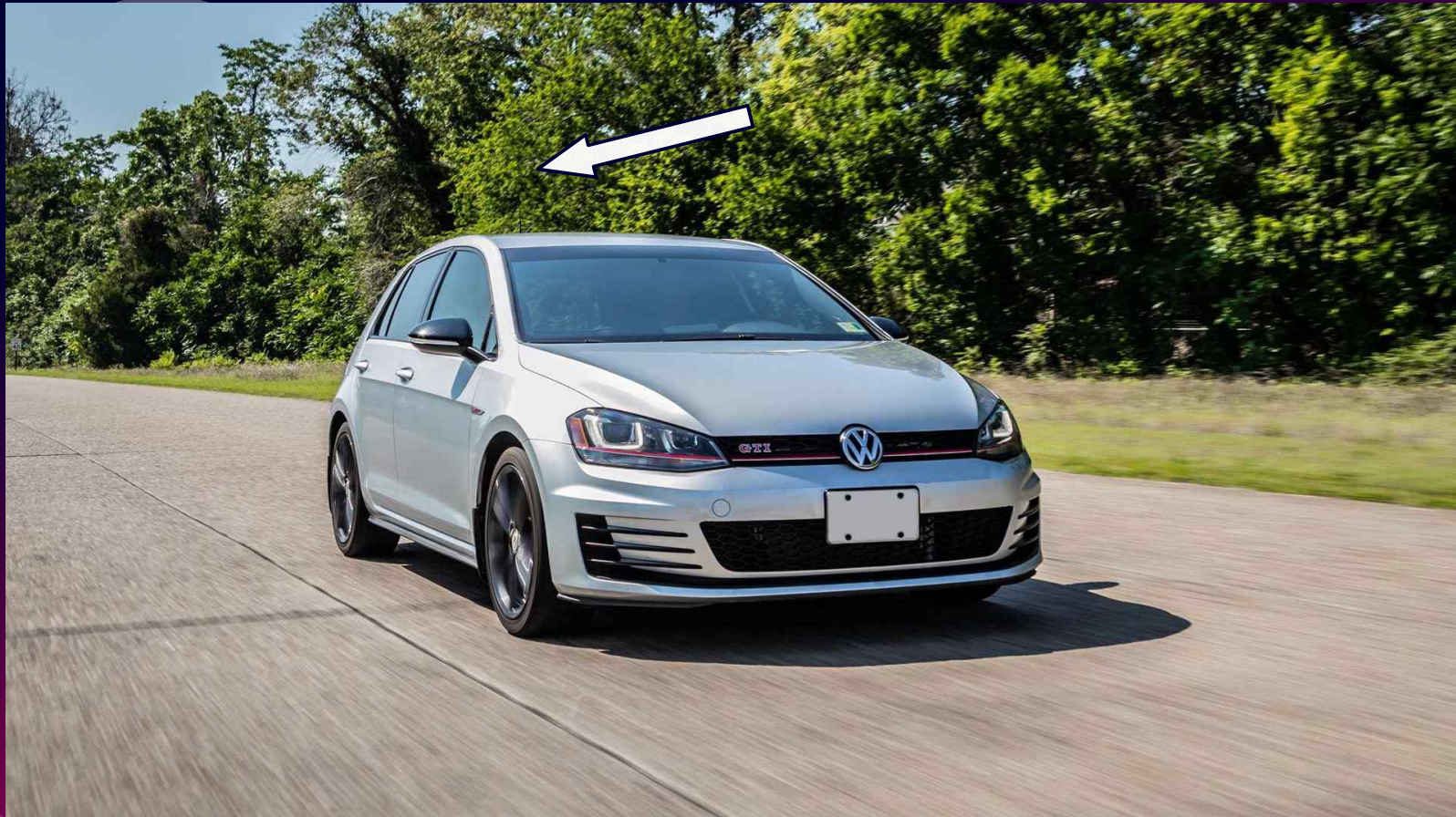

2.0 TSI EA888 Gen 3 (210 PS) - 91 (R+M)/2  
APR Stage 3 IS38 High Torque ECU Upgrade vs Stock

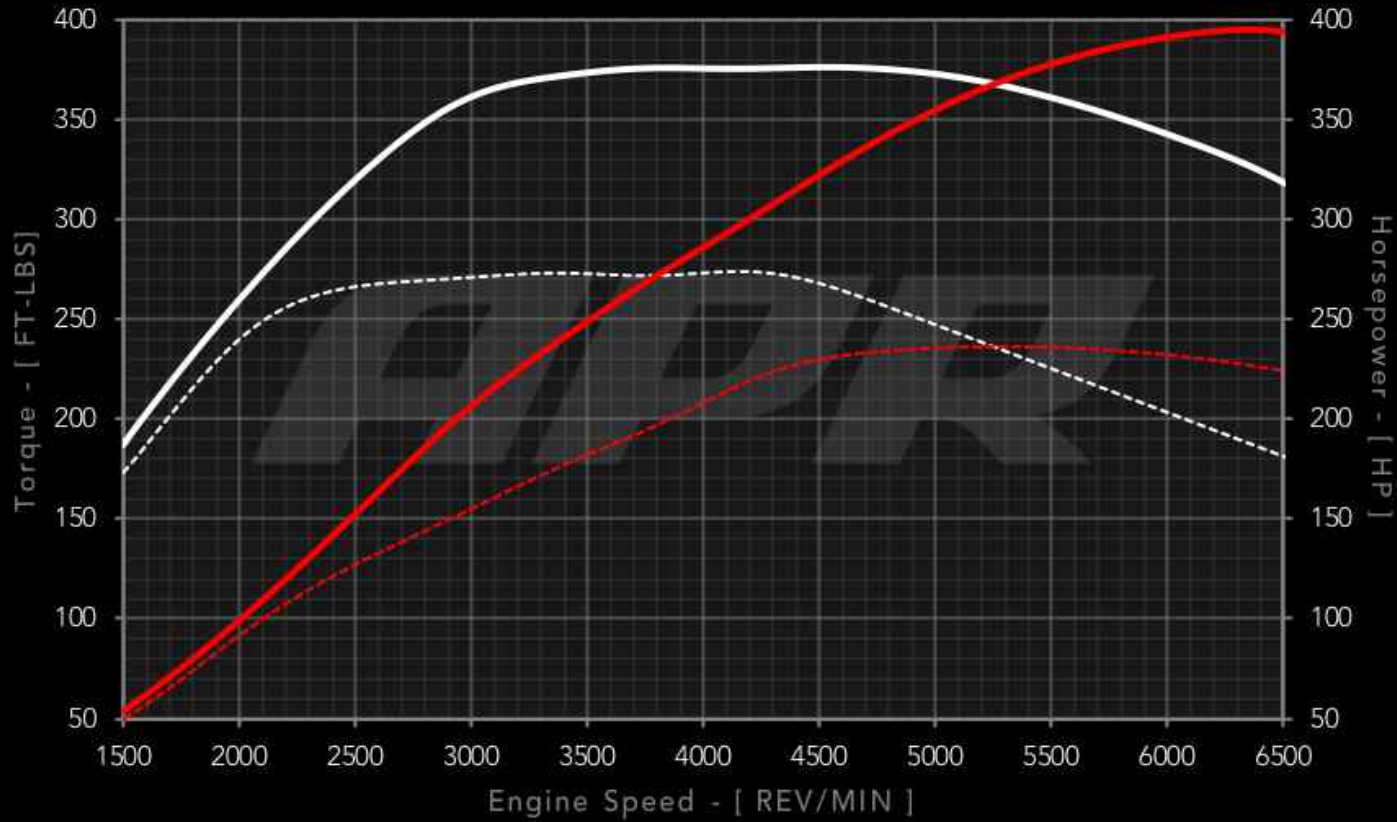

----- Stock 274 TQ

———— APR 376 TQ

----- Stock 236 HP

———— APR 395 HP

2020

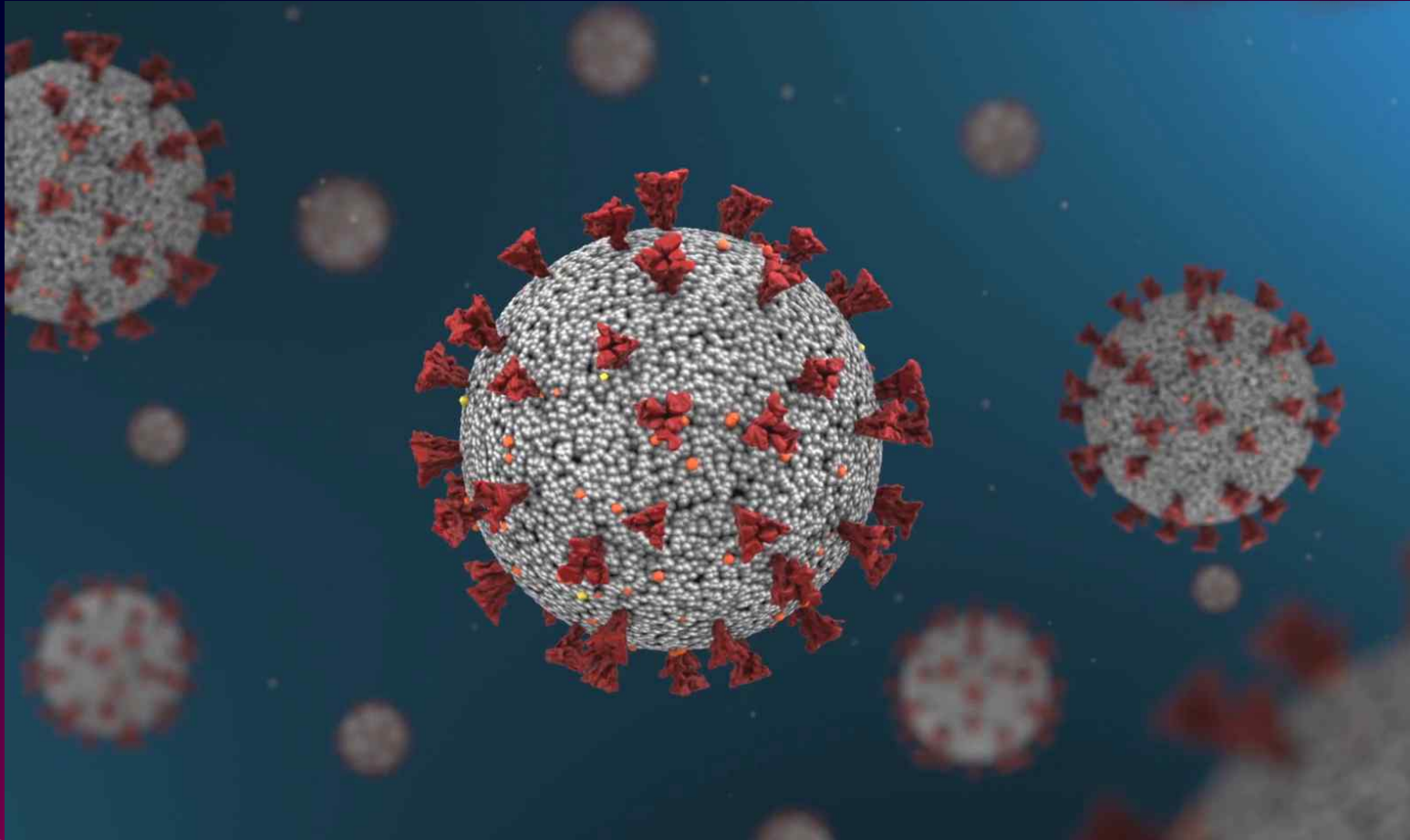

# “Limited Rover”



# Daily View



# Wearing the Station







# Mics and Speakers

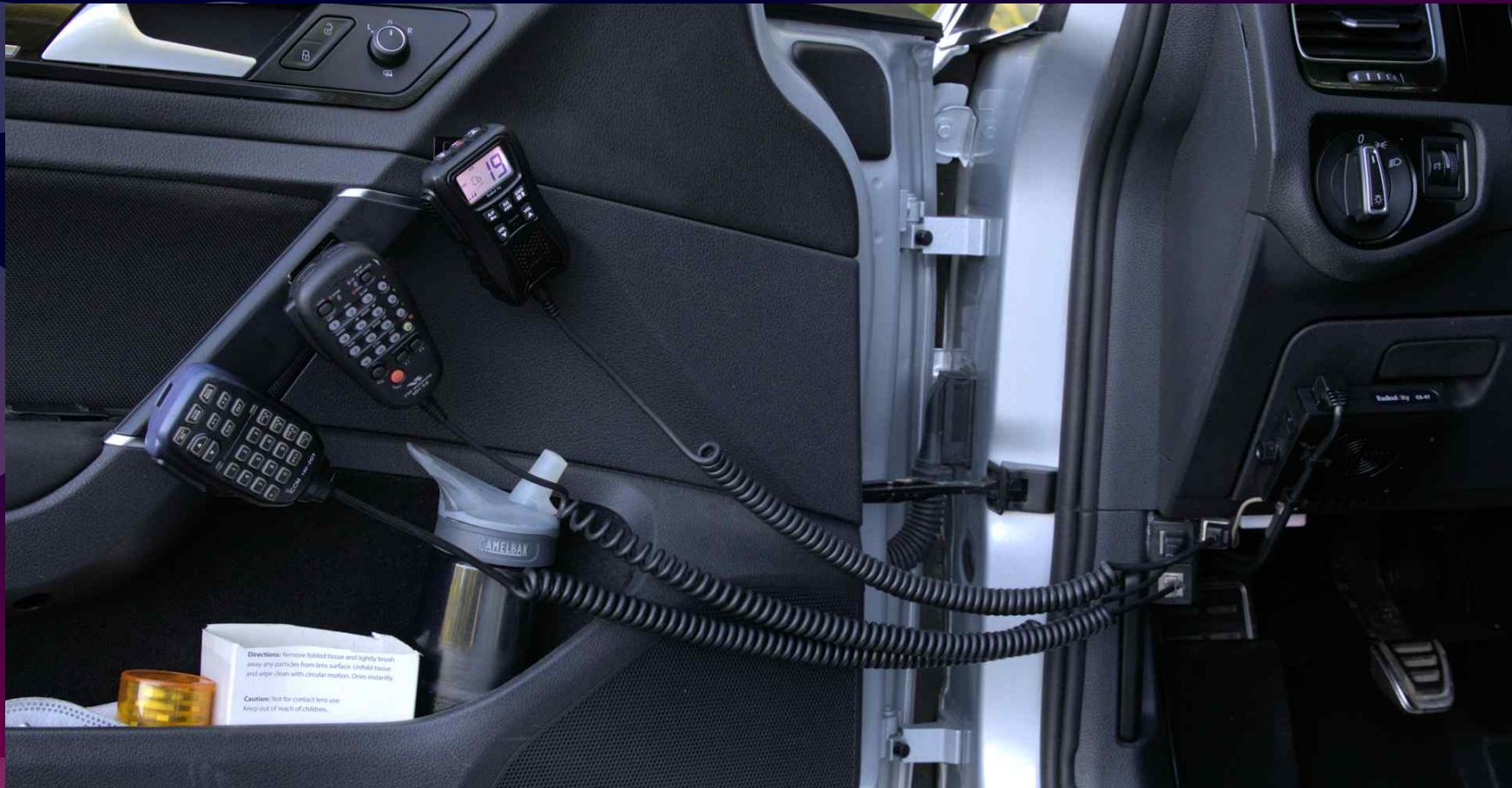

# Mics and Speakers



# Heil Pro 7 Headset

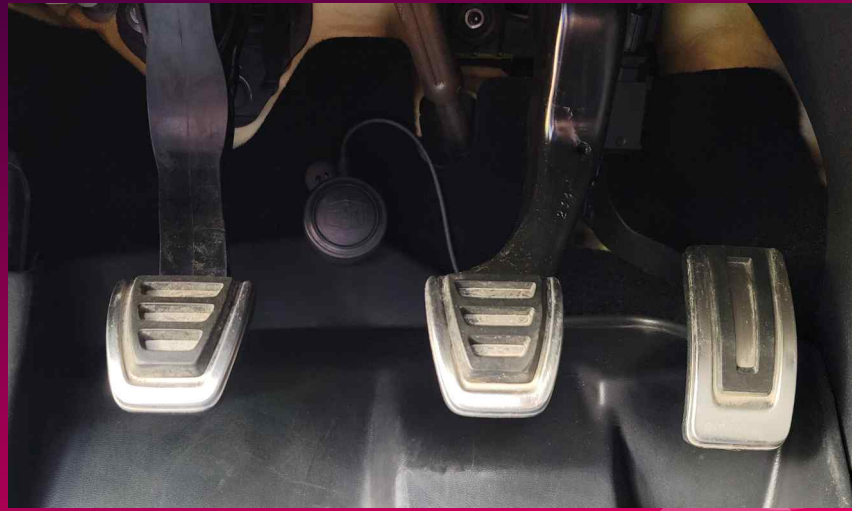





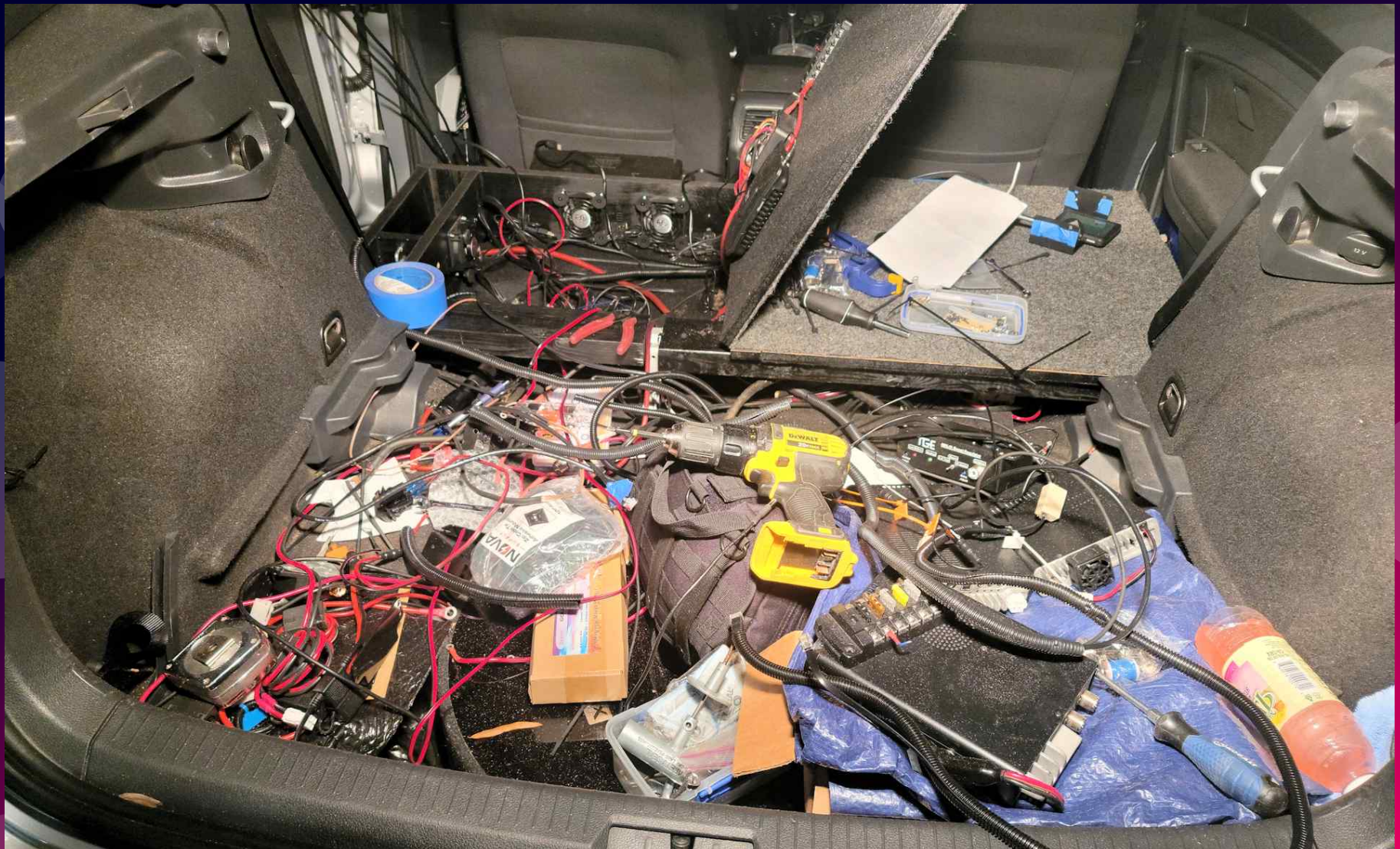

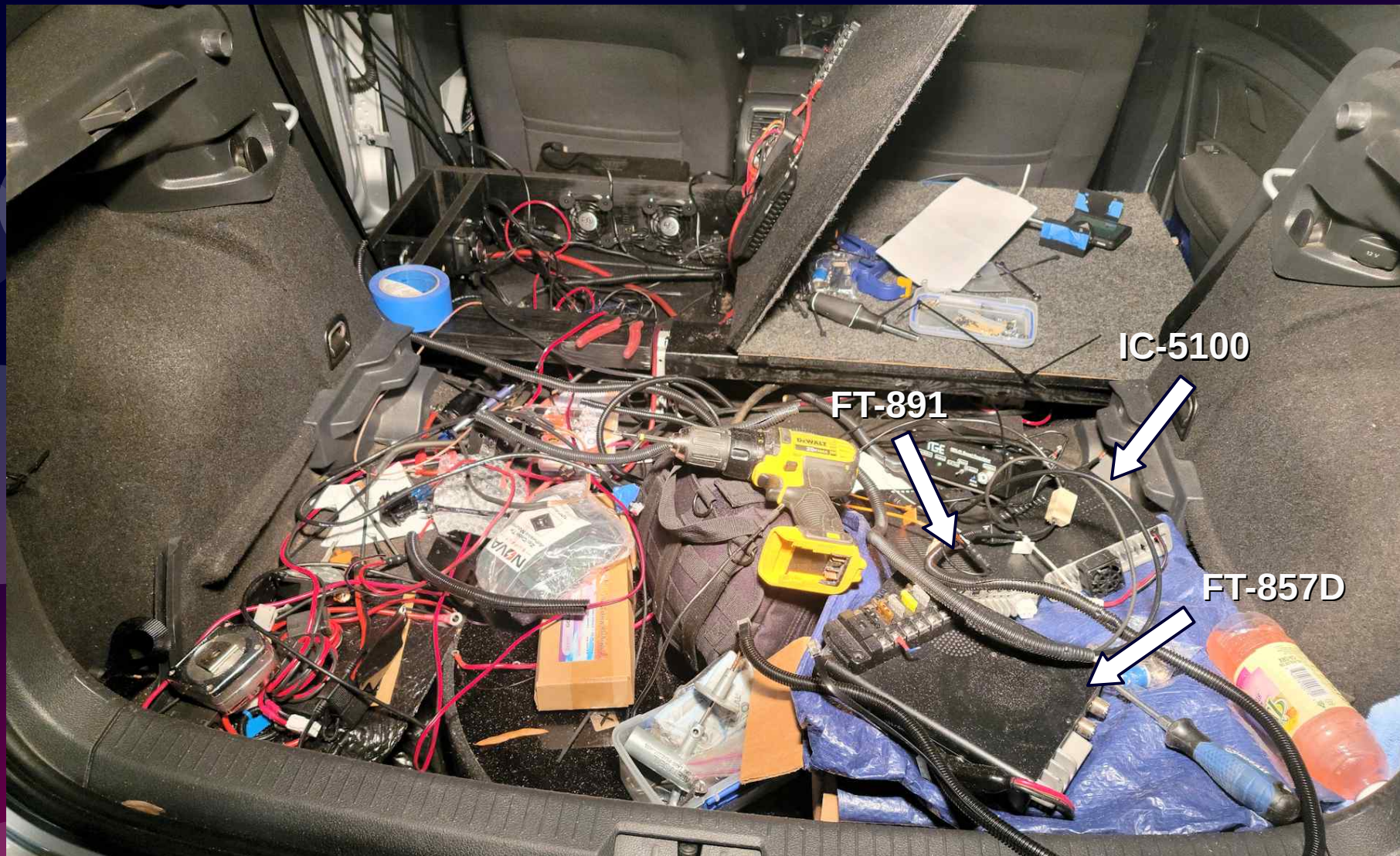

FT-891

IC-5100

FT-857D

# A Floor Beneath a Floor



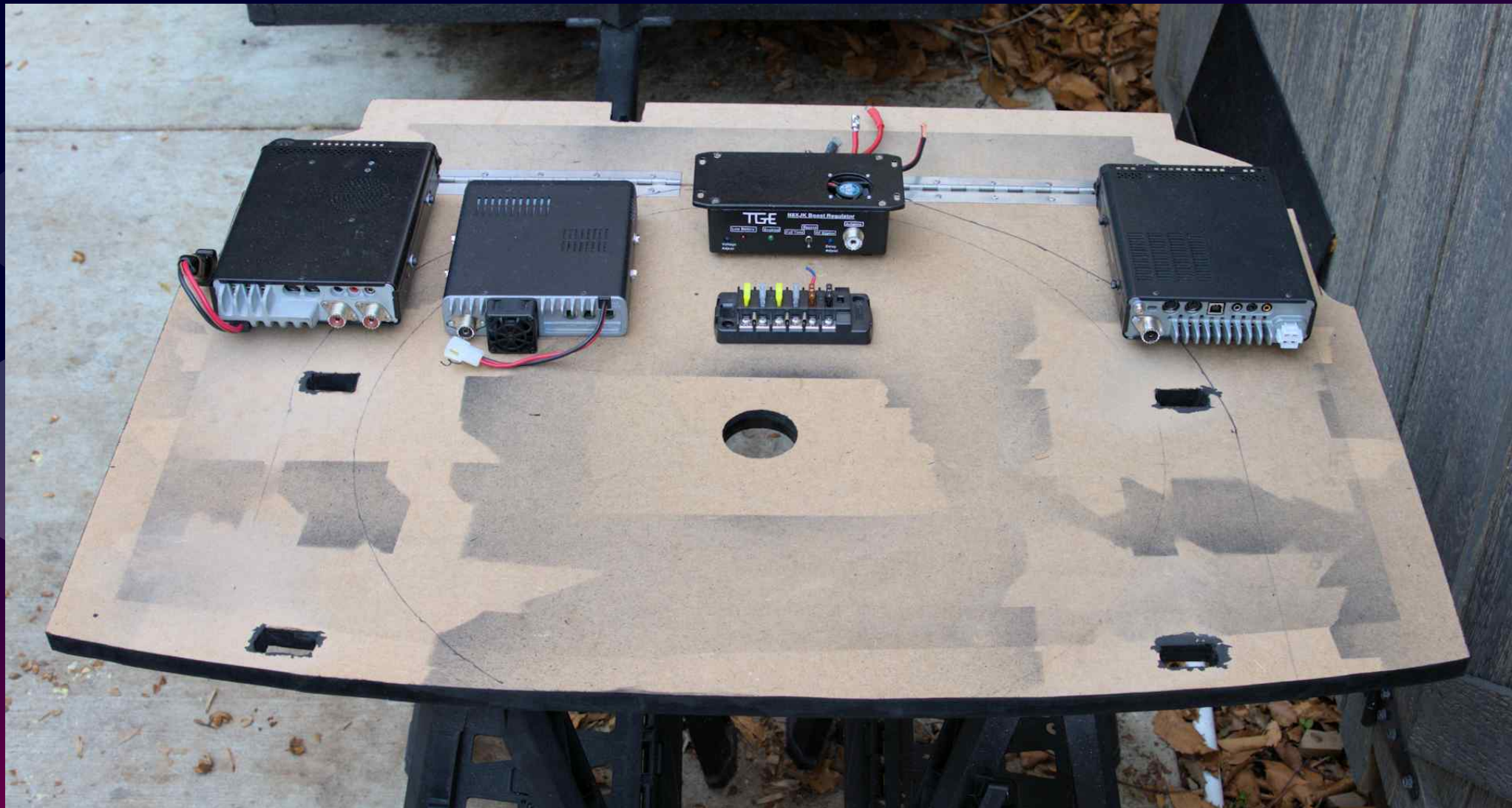

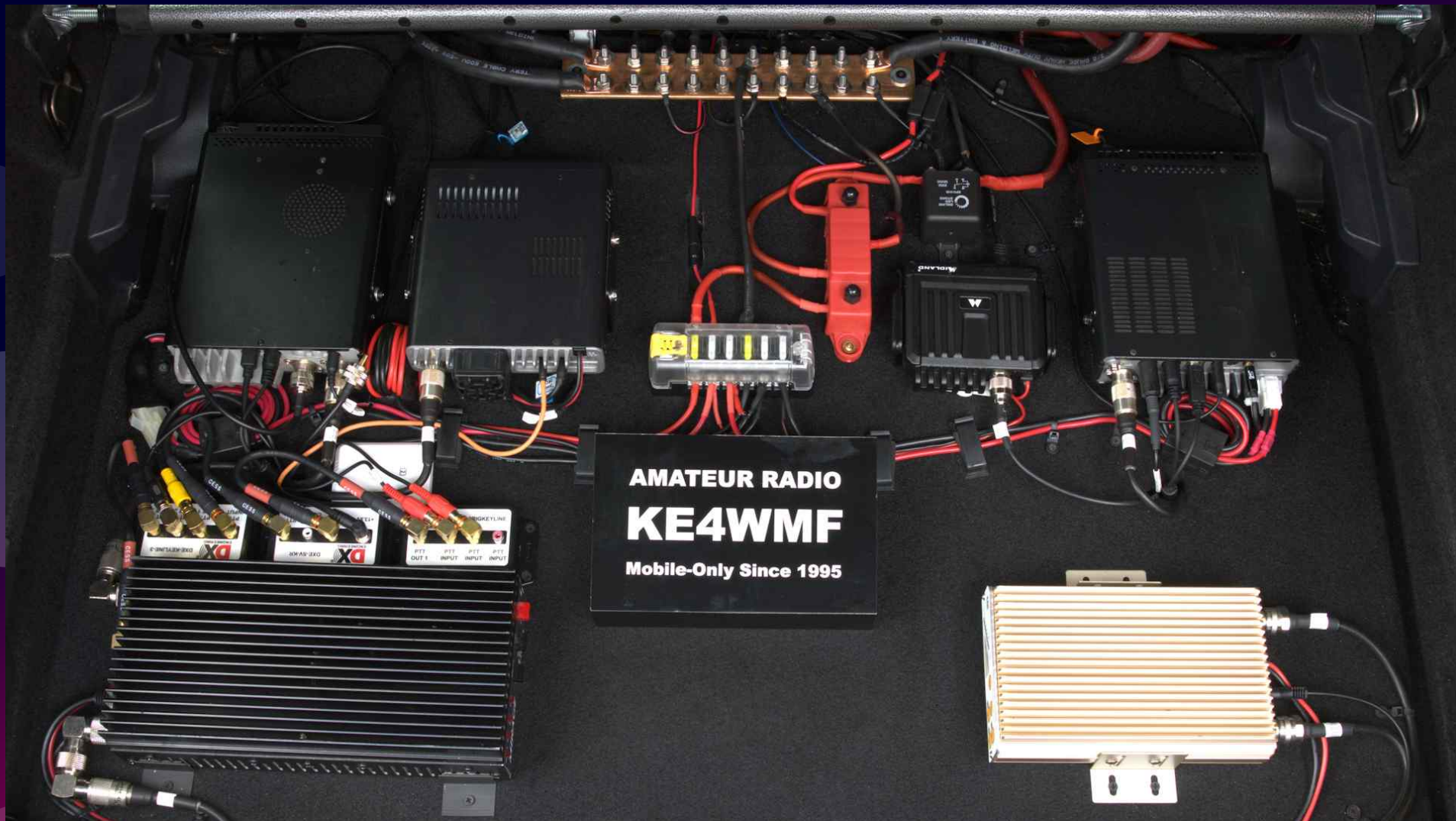

**AMATEUR RADIO**  
**KE4WMF**  
Mobile-Only Since 1995



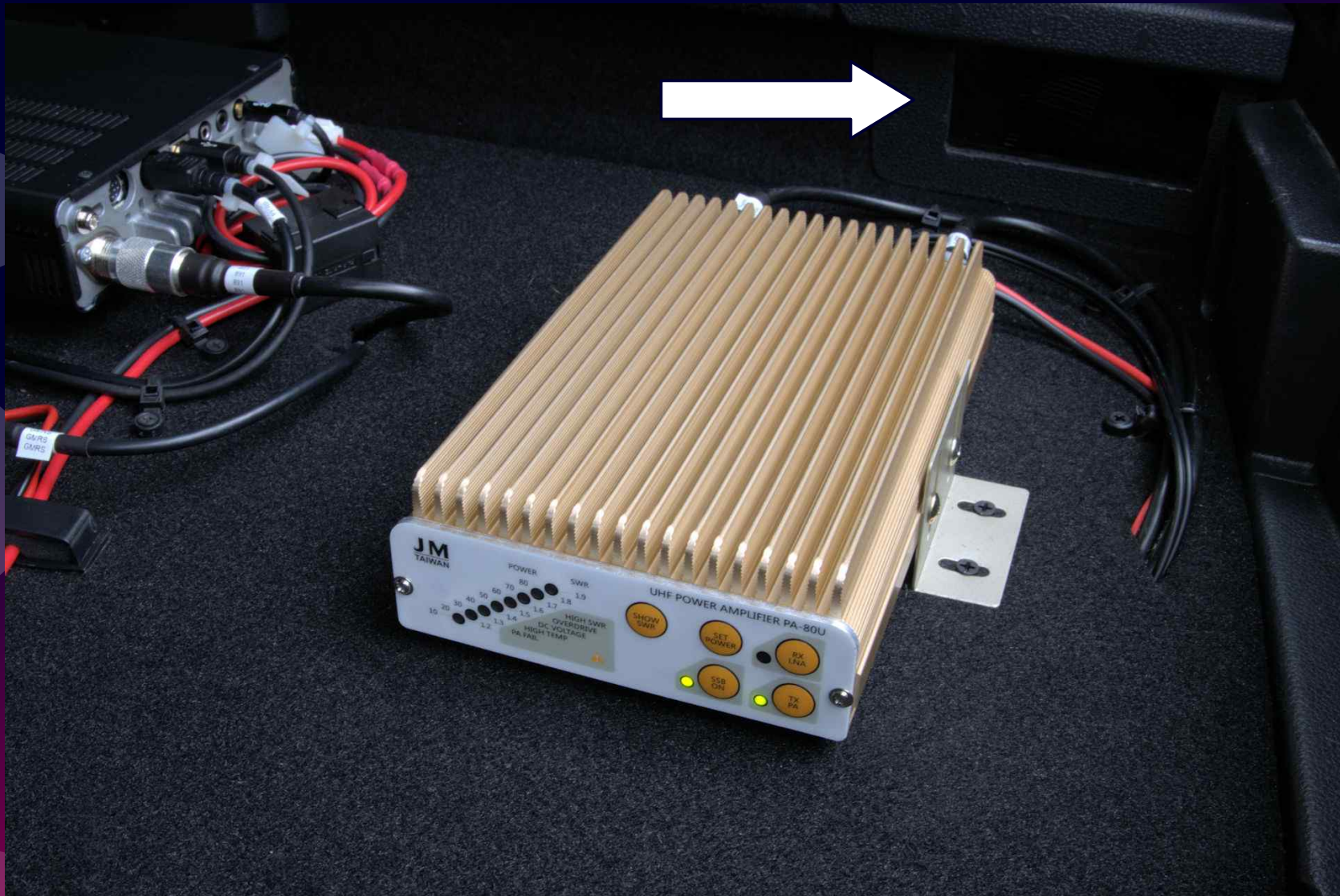



# Notional Airflow Path Beneath Trunk Floor

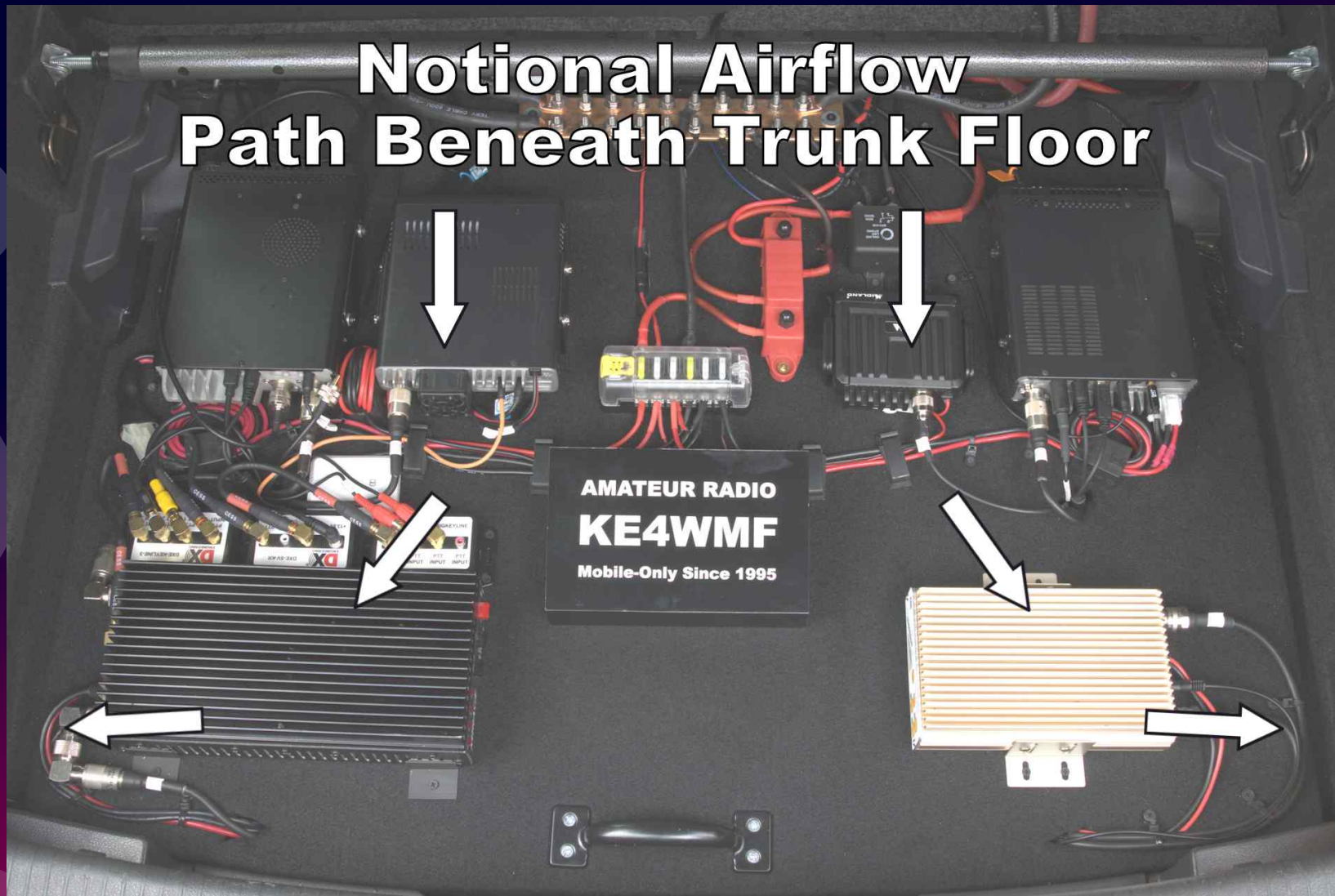

# Functional Cargo Floor



# Functional Cargo Floor





# POWER DISTRIBUTION

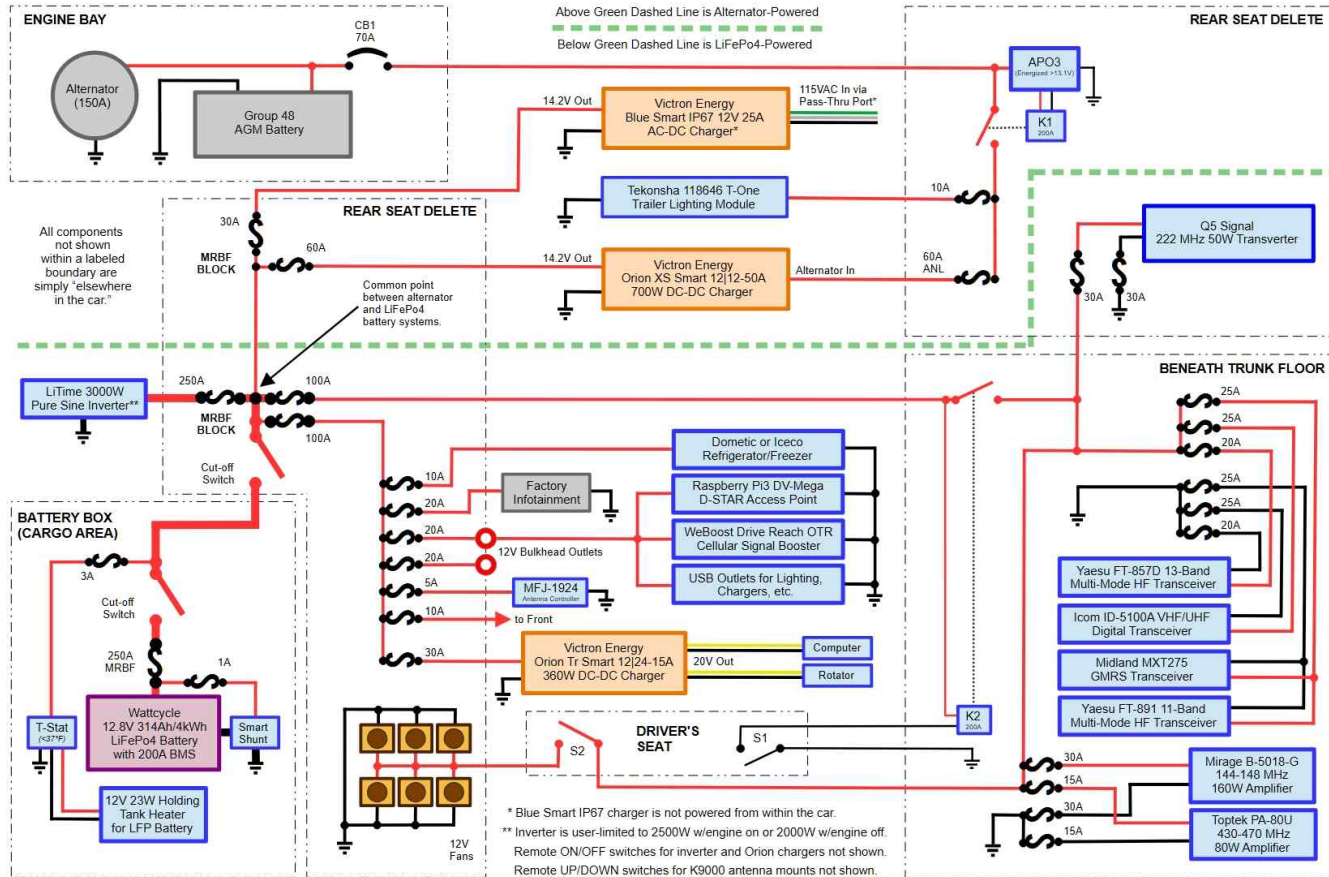

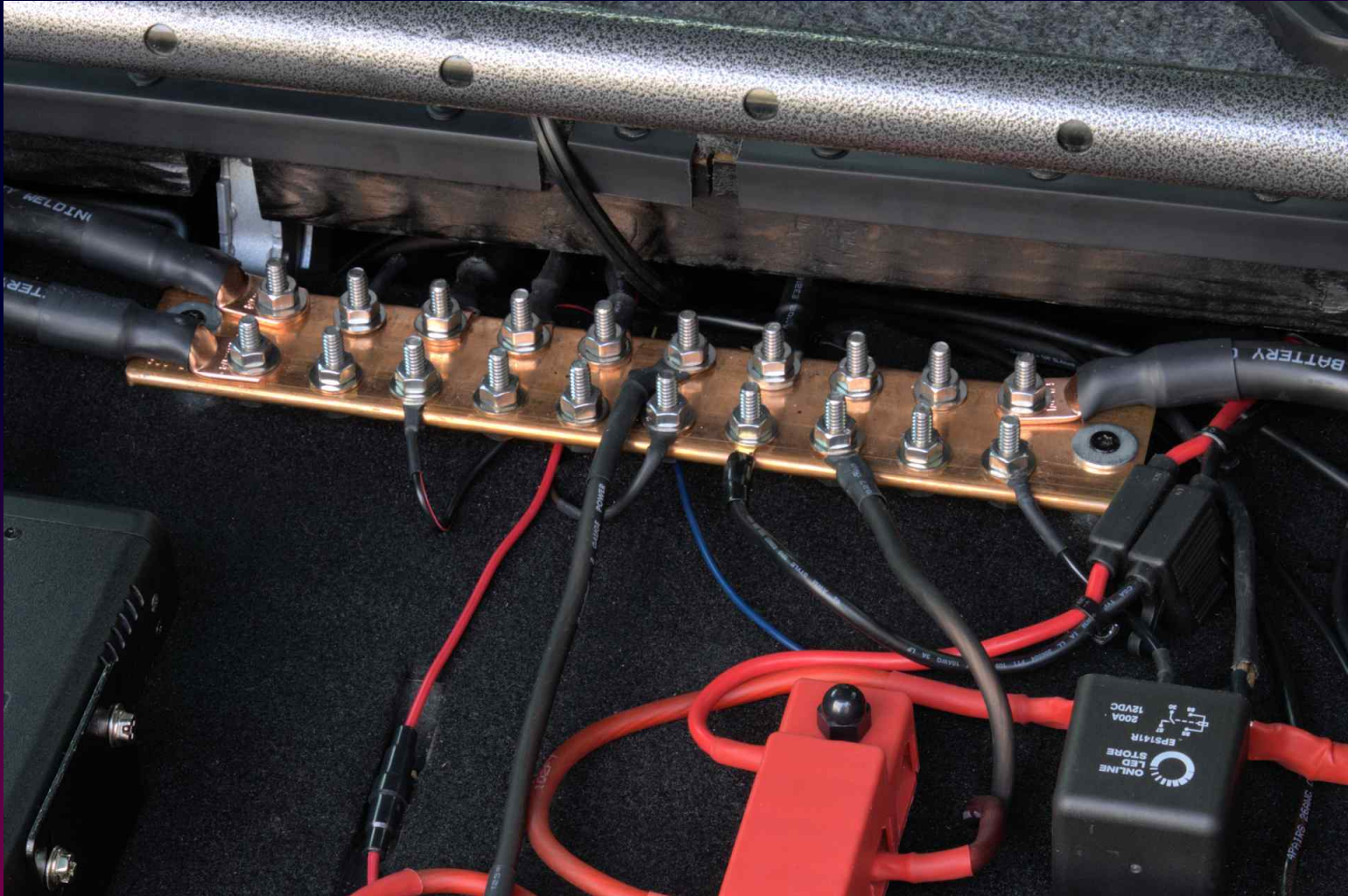



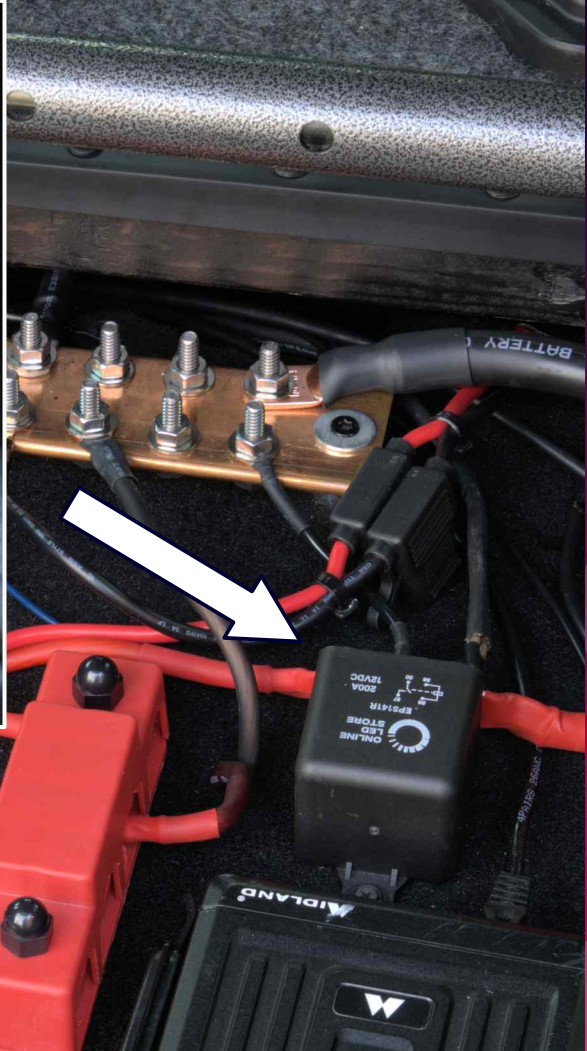

# 12V 314Ah (4,019Wh) LiFePo4



# 12V 314Ah (4,019Wh) LiFePo4





# DC-DC Charger





# AC-DC Charger



# 12V Distribution

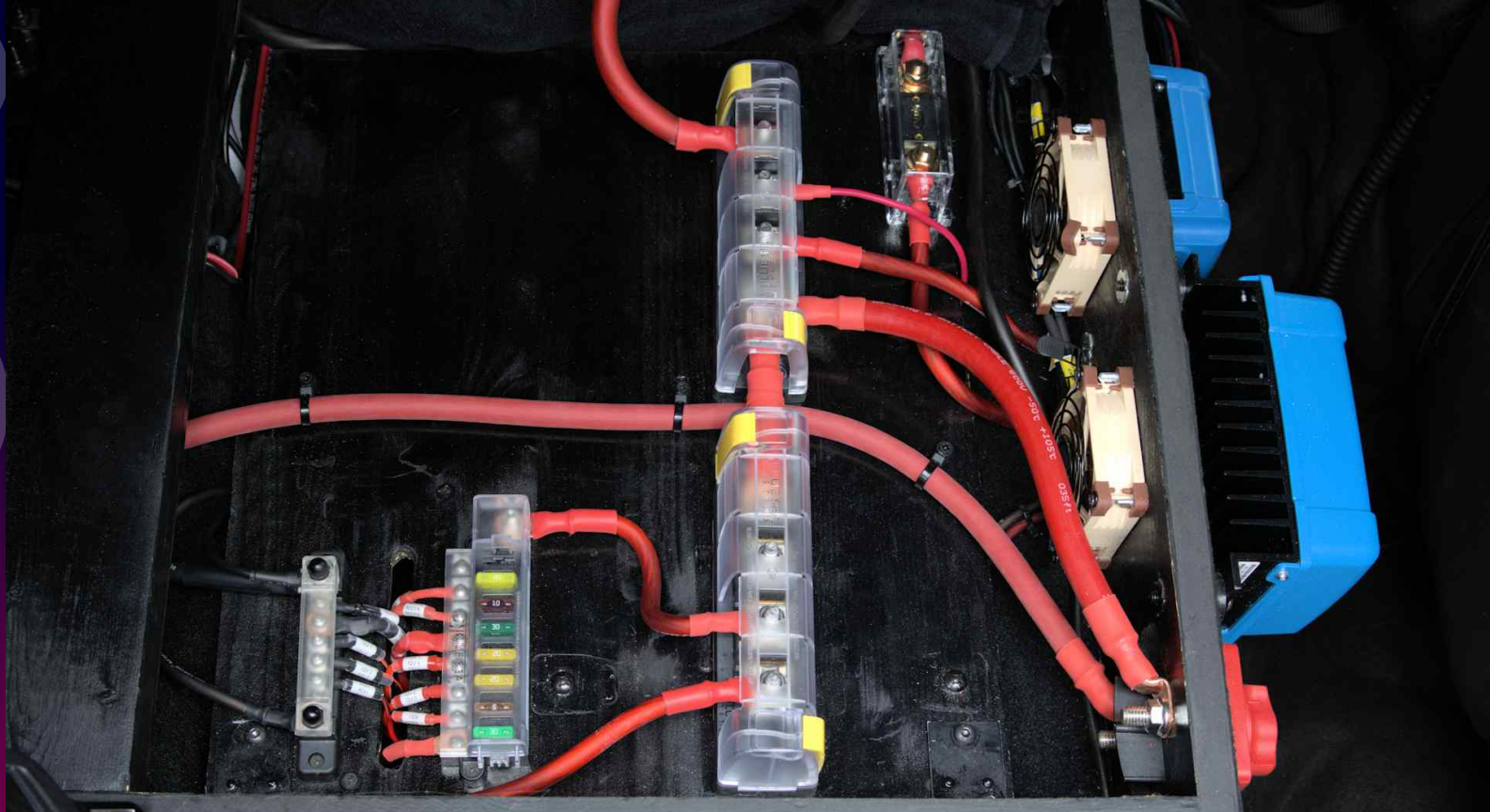

# Fridge and Household Power



# Antenna Farm

**12 Bands\***

**80/60/40/30/20/15/12/10**

**6/2/222/432**

**7 Verticals**

**4 Horizontals**

**3 Configurations**

**\*Not including CB, GMRS,  
Meshtastic, and WeBoost**

**4 Diamond K9000**

**Motorized Antenna Mounts**



# K9000 Motorized Mounts



# FT-891 Antenna Options

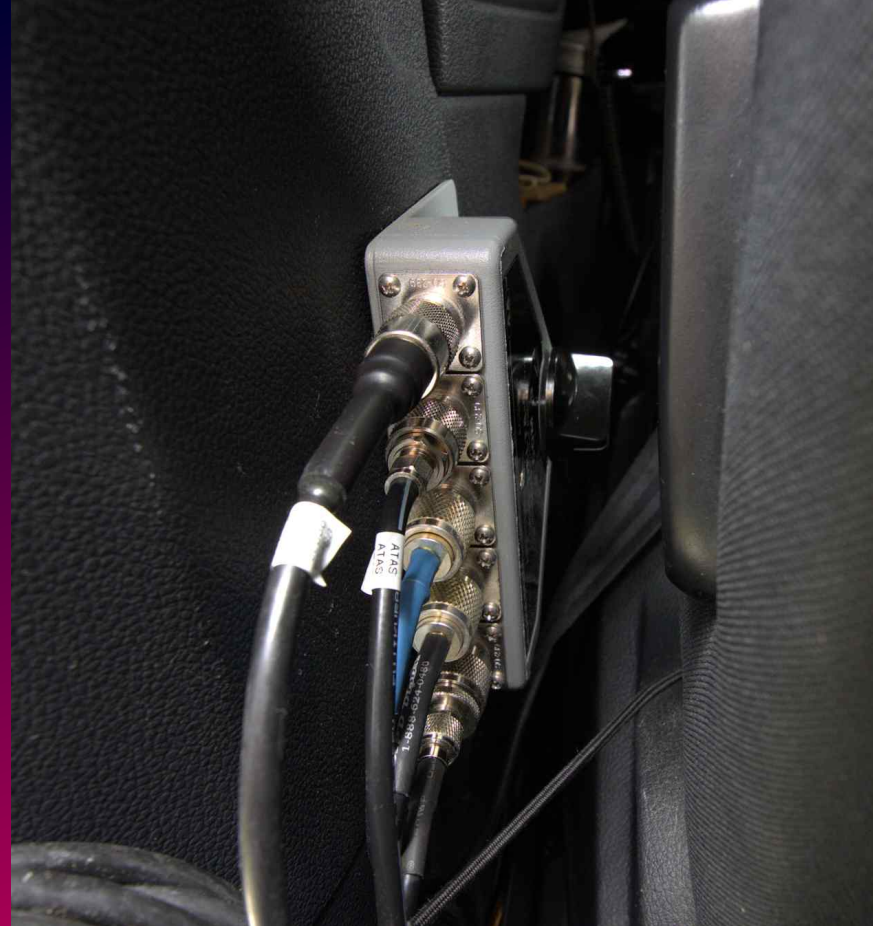

# Yaesu ATAS-120A



# Yaesu ATAS-120A



# Scorpion SA-680BW and M<sup>2</sup>Inc 6m



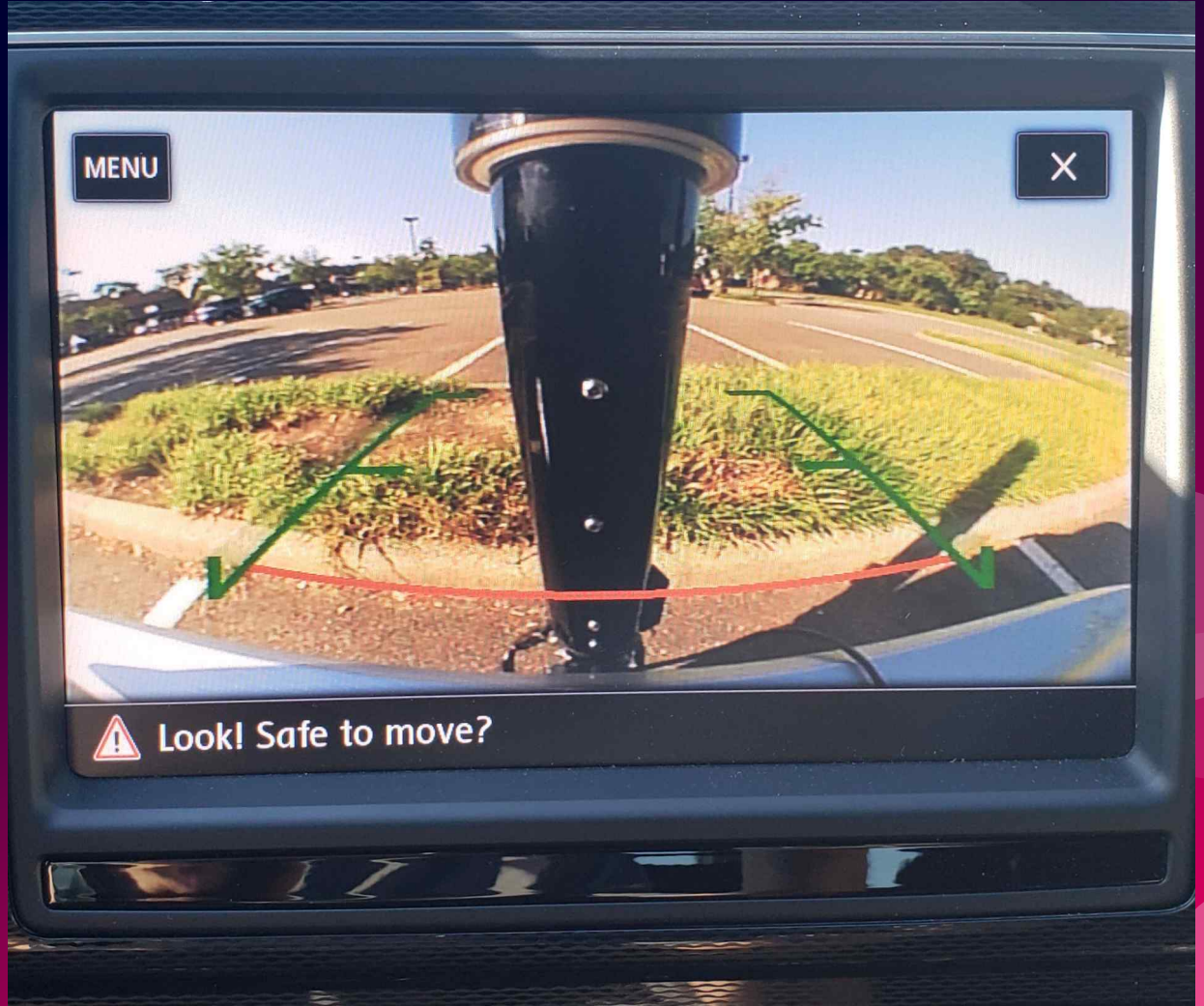



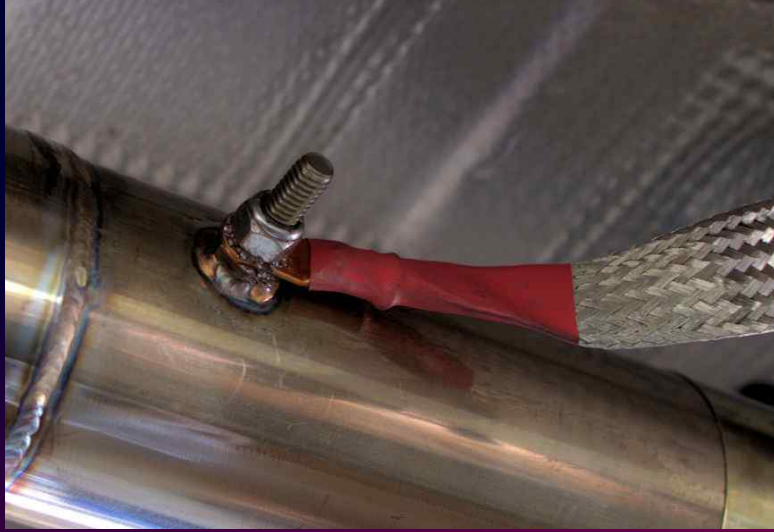

# Contest Setup

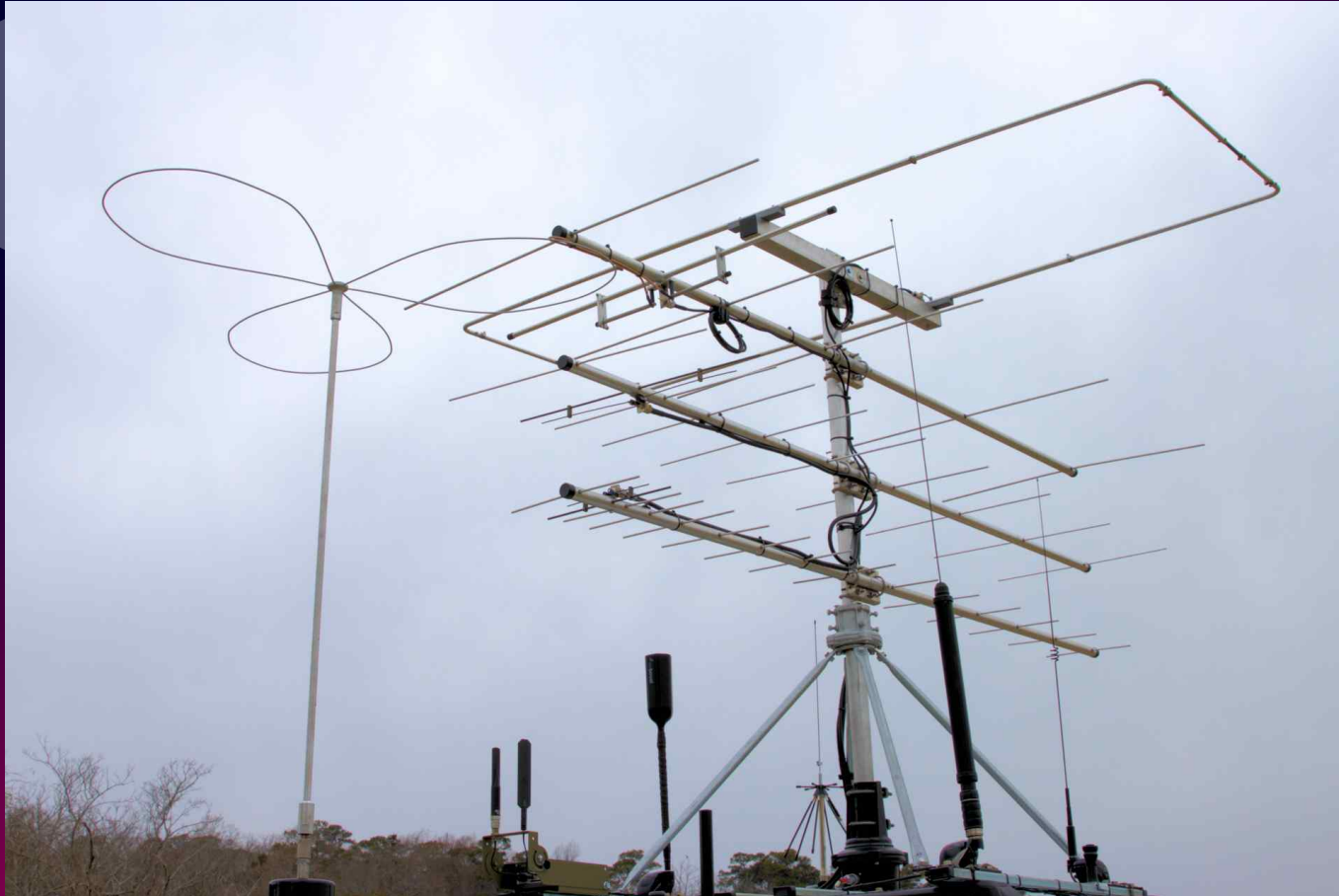

# Contest Setup

Each Yagi = ~4 lbs  
 Remaining Feed Line and Hardware  
 Above the Tower Bearing is ~15 lbs

Overall Height Above  
 Superstrut = ~66"  
 Overall Height Above  
 Ground = ~10'8"

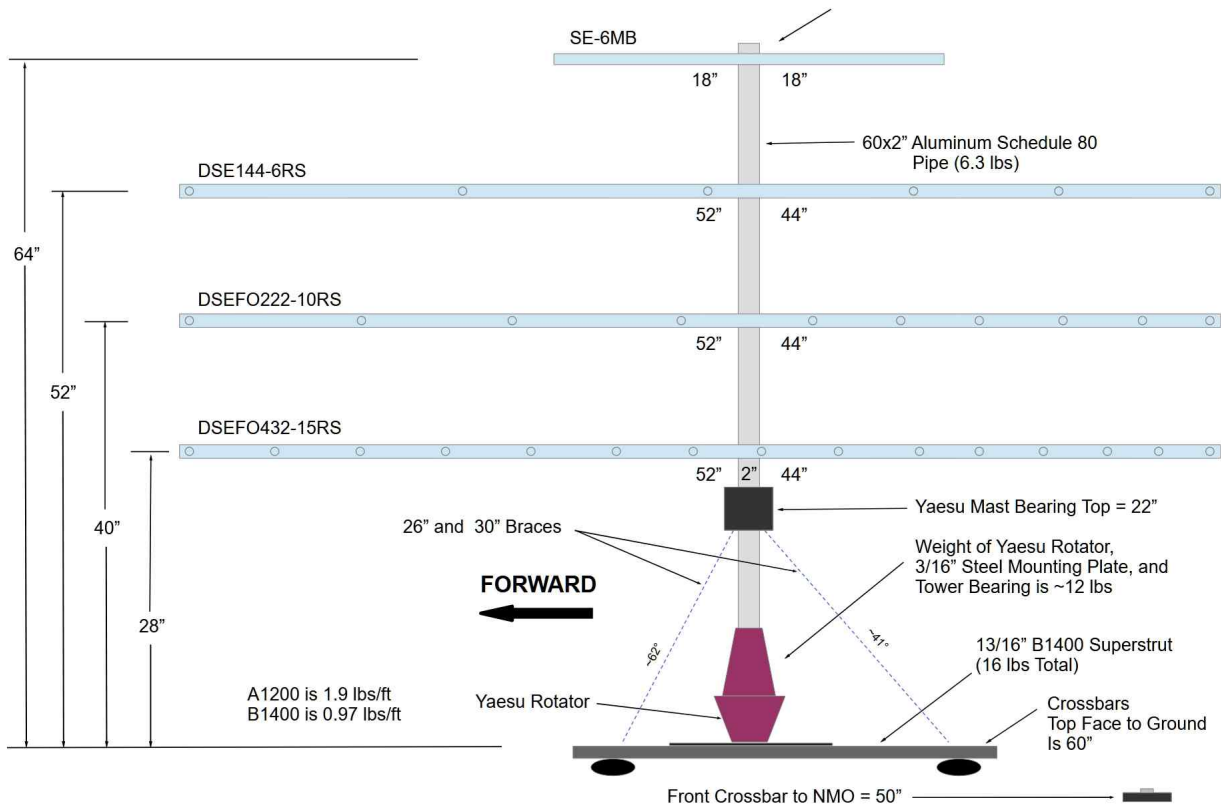

# Antenna Planters

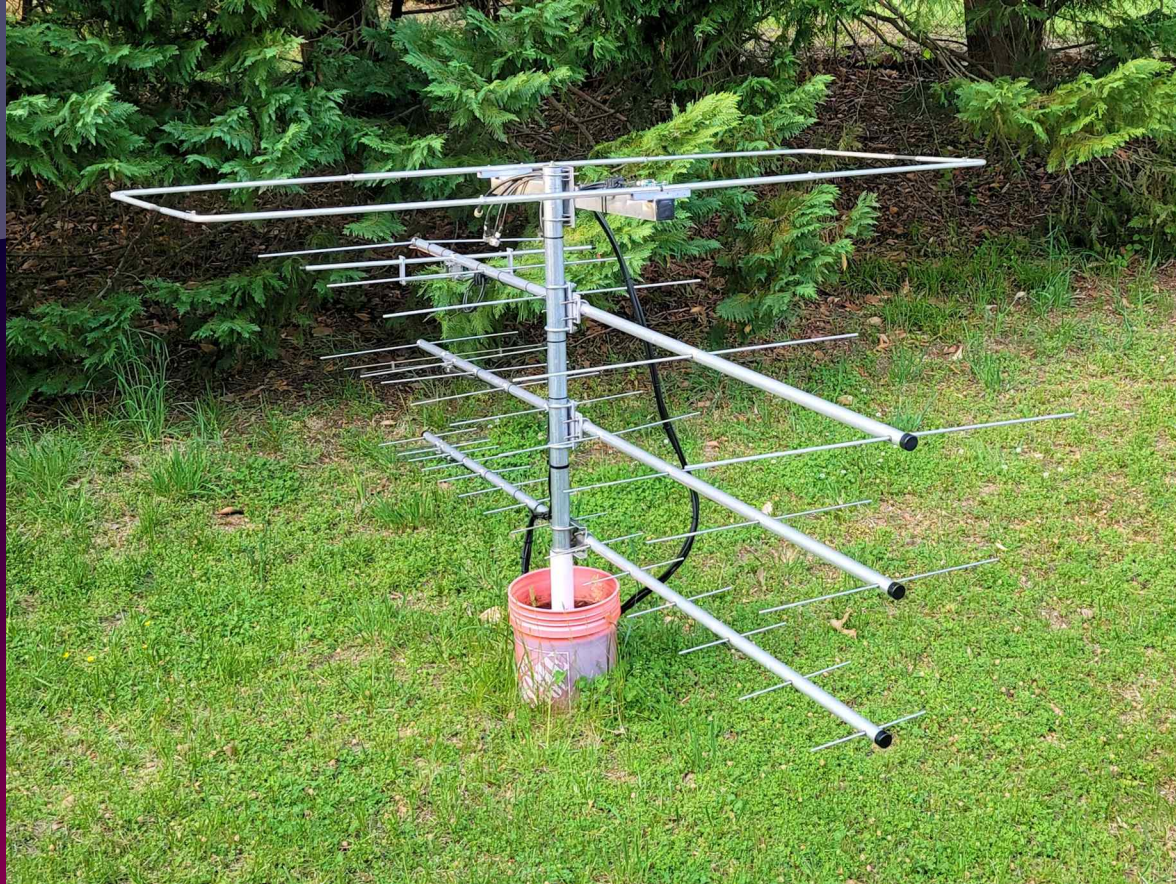

# Contest Setup



# Feed Line Pass-Through



# SDRPlay



# Miscellaneous

GPS Receiver for Timing



222 MHz Transverter



Meshtastic Node



Elex Panel in Service Position



Empty Tire Well

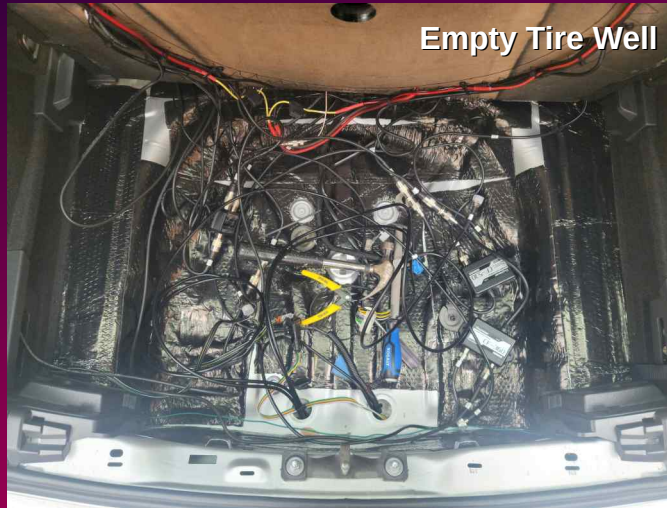

USB Hub for Cable Consolidation



# QUESTIONS?



# YES!







Love at first sight

# Texas VHF Crew (Grid-Circling)



# 4Runner – Part-time Contester



# Ultra-Compact!





Love at first sight